

## FEATURES

- **SUPER LOW NOISE FIGURE:**  
0.35 dB TYP at  $f = 12$  GHz
- **HIGH ASSOCIATED GAIN:**  
13.5 dB TYP at  $f = 12$  GHz
- **GATE LENGTH:**  $L_G \leq 0.20 \mu\text{m}$
- **GATE WIDTH:**  $W_G = 160 \mu\text{m}$

## DESCRIPTION

NEC's NE3210S01 is a pseudomorphic Hetero-Junction FET that uses the junction between Si-doped AlGaAs and undoped InGaAs to create very high mobility electrons. The device features mushroom shaped TiAl gates for decreased gate resistance and improved power handling. Its excellent low noise figure and high associated gain make it suitable for DBS and commercial systems. The NE 3210S01 is housed in a low cost plastic package which is available in tape and reel.

NEC's stringent quality assurance and test procedures assure the highest reliability and performance.

## OUTLINE DIMENSION (Units in mm)

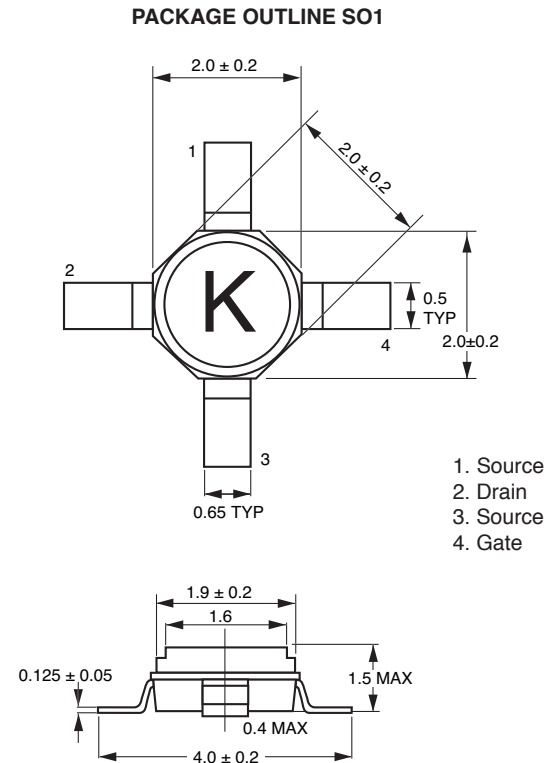

## ELECTRICAL CHARACTERISTICS ( $T_A = 25^\circ\text{C}$ )

PART NUMBER PACKAGE OUTLINE			NE3210S01 S01		
SYMBOLS	PARAMETERS AND CONDITIONS	UNITS	MIN	TYP	MAX
GA	Associated Gain <sup>1</sup> , $V_{DS} = 2$ V, $I_D = 10$ mA, $f = 12$ GHz	dB	12	13.5	
NF	Noise Figure <sup>1</sup> , $V_{DS} = 2$ V, $I_D = 10$ mA, $f = 12$ GHz	dB		0.35	0.45
$g_m$	Transconductance, $V_{DS} = 2$ V, $I_D = 10$ mA	mS	40	55	
$I_{DSS}$	Saturated Drain Current, $V_{DS} = 2$ V, $V_{GS} = 0$ V	mA	15	40	70
$V_P$	Gate to Source Cutoff Voltage, $V_{DS} = 2$ V, $I_D = 100 \mu\text{A}$	V	-0.2	-0.7	-2.0
$I_{GSO}$	Gate to Source Leakage Current, $V_{GS} = -3$ V	$\mu\text{A}$		0.5	10

Note:

1. Typical values of noise figures and associated gain are those obtained when 50% of the devices from a large number of lots were individually measured in a circuit with the input individually tuned to obtain the minimum value. Maximum values are criteria established on the production line as a "go-no-go" screening tuned for the "generic" type but not each specimen.

**ABSOLUTE MAXIMUM RATINGS<sup>1</sup>** (T<sub>A</sub> = 25°C)

SYMBOLS	PARAMETERS	UNITS	RATINGS
V <sub>DS</sub>	Drain to Source Voltage	V	4.0
V <sub>GS</sub>	Gate to Source Voltage	V	-3.0
I <sub>DS</sub>	Drain Current	mA	I <sub>DSS</sub>
I <sub>GS</sub>	Gate Current	μA	100
P <sub>T</sub>	Total Power Dissipation	mW	165
T <sub>CH</sub>	Channel Temperature	°C	125
T <sub>STG</sub>	Storage Temperature	°C	-65 to +125

Note:

1. Operation in excess of any one of these parameters may result in permanent damage.

**TYPICAL MOUNT PAD LAYOUT** (Units in mm)

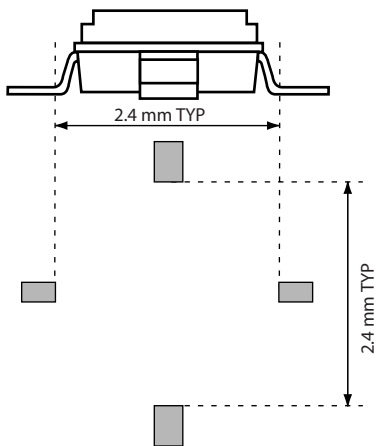

**RECOMMENDED OPERATING CONDITIONS** (T<sub>A</sub> = 25°C)

PART NUMBER			NE3210S01		
SYMBOLS	PARAMETERS	UNITS	MIN	TYP	MAX
V <sub>DS</sub>	Drain to Source Voltage	V		2	3
I <sub>DS</sub>	Drain Current	mA		10	15
P <sub>IN</sub>	Input Power	dBm			0

**TYPICAL NOISE PARAMETERS** (T<sub>A</sub> = 25°C)

FREQ. (GHz)	NF <sub>MIN</sub> (dB)	G <sub>A</sub> (dB)	Γ <sub>OPT</sub>		R <sub>n/50</sub>
			MAG	ANG	
<b>V<sub>DS</sub> = 2 V, I<sub>D</sub> = 10 mA</b>					
2.0	0.25	21.2	0.94	12	0.38
4.0	0.26	19.5	0.80	26	0.33
6.0	0.28	18.2	0.66	44	0.26
8.0	0.30	16.2	0.50	68	0.18
10.0	0.32	14.7	0.38	97	0.11
12.0	0.34	13.5	0.29	133	0.09
14.0	0.42	12.9	0.27	177	0.08
16.0	0.56	12.3	0.33	-129	0.11
18.0	0.72	11.9	0.39	-82	0.23

**ORDERING INFORMATION**

PART NUMBER	SUPPLY FORM	MARKING
NE3210S01-T1	Tape & Reel 1000 pcs/reel	K
NE3210S01-T1B	Tape & Reel 4000 pcs/reel	

**TYPICAL PERFORMANCE CURVES** ( $T_A = 25^\circ\text{C}$ )

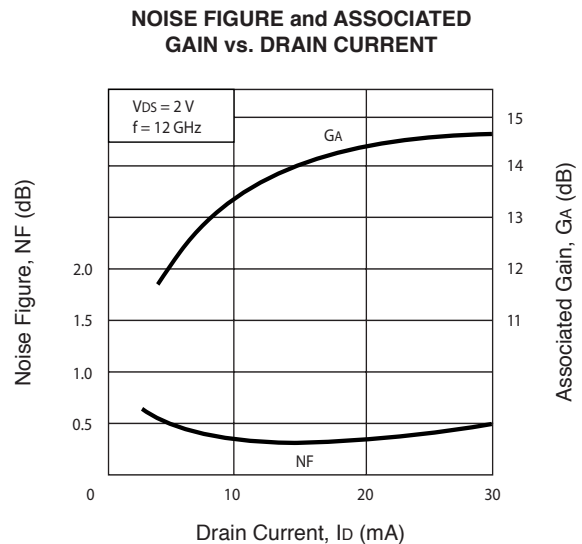
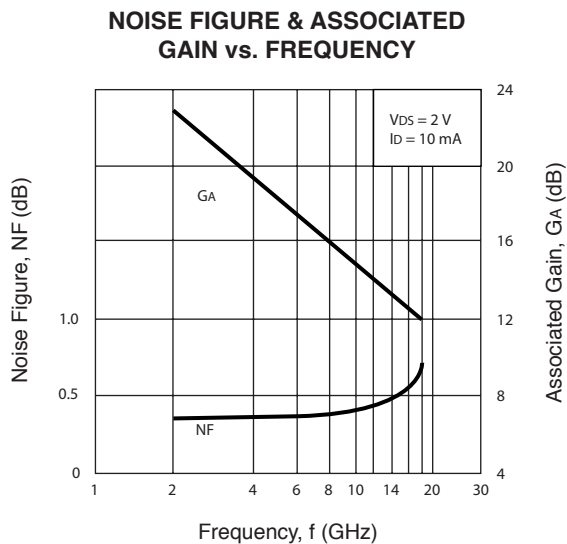
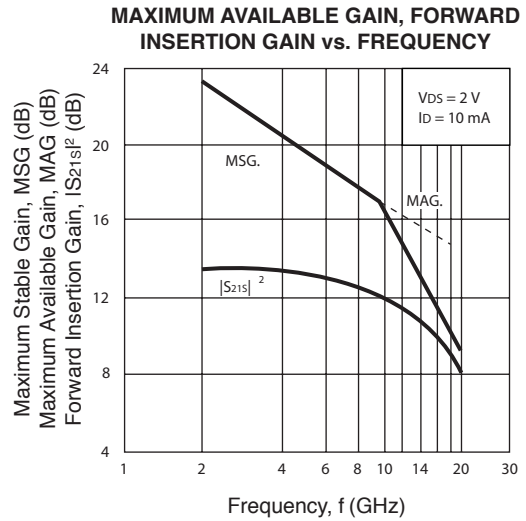
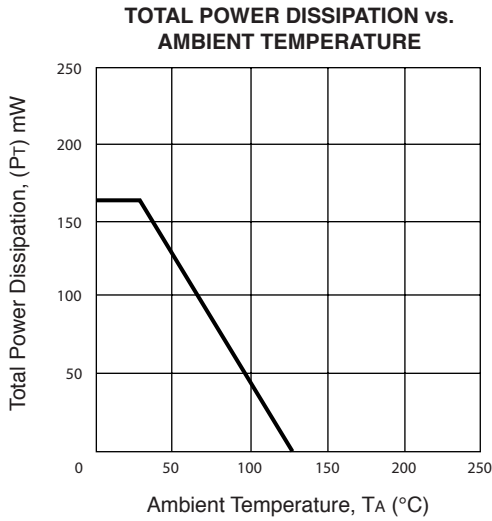
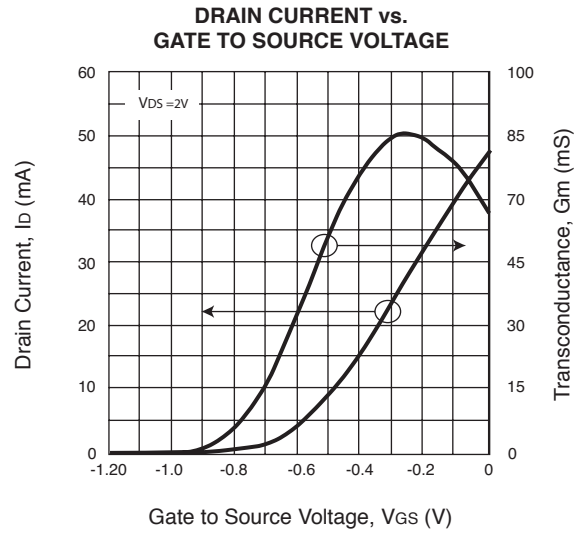
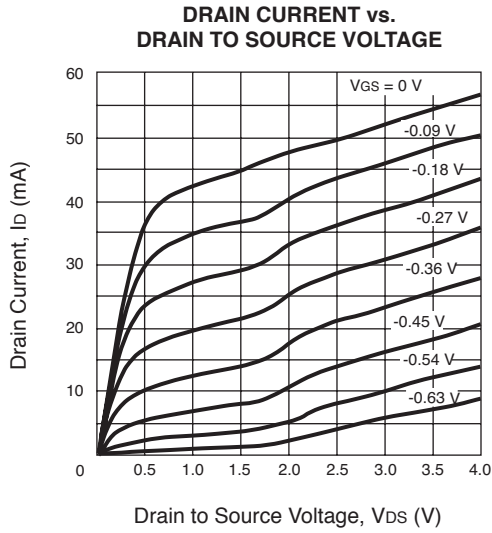

TYPICAL SCATTERING PARAMETERS (TA = 25°C)

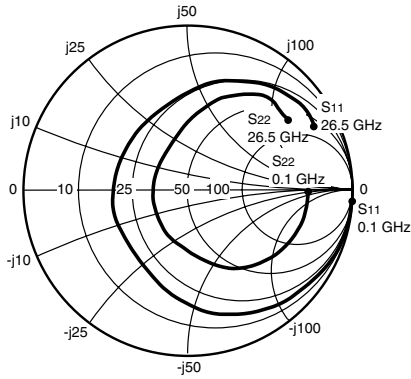

Coordinates in Ohms  
Frequency in GHz  
V<sub>D</sub> = 2 V, I<sub>D</sub> = 5 mA

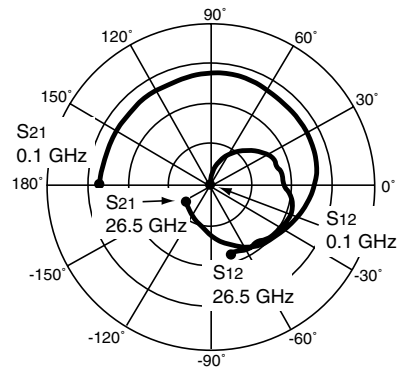

NE3210S01  
V<sub>D</sub> = 2 V, I<sub>D</sub> = 5 mA

FREQUENCY	S <sub>11</sub>		S <sub>21</sub>		S <sub>12</sub>		S <sub>22</sub>		K	MAG <sup>1</sup>
GHz	MAG	ANG	MAG	ANG	MAG	ANG	MAG	ANG		(dB)
0.10	1.001	-1.14	3.405	178.54	0.001	82.96	0.732	-0.85	-0.03	34.20
0.20	1.000	-2.12	3.393	177.73	0.003	88.10	0.731	-1.97	0.00	30.64
0.30	1.000	-3.08	3.393	176.83	0.004	88.76	0.732	-3.04	-0.03	28.99
0.40	0.999	-4.18	3.396	175.50	0.006	86.87	0.732	-3.93	0.04	27.65
0.50	0.997	-4.94	3.345	173.68	0.007	85.87	0.735	-4.73	0.08	26.76
0.70	0.995	-6.83	3.347	171.18	0.010	84.12	0.735	-6.68	0.11	25.30
1.00	0.992	-10.11	3.350	167.44	0.014	81.51	0.732	-9.24	0.12	23.77
1.50	0.987	-15.20	3.346	161.27	0.021	77.55	0.726	-13.91	0.15	22.03
2.00	0.978	-20.81	3.362	154.97	0.028	73.36	0.718	-18.29	0.19	20.82
2.50	0.968	-26.46	3.373	148.74	0.035	69.02	0.709	-22.77	0.23	19.89
3.00	0.954	-32.09	3.388	142.45	0.041	64.57	0.698	-27.41	0.27	19.15
3.50	0.938	-37.61	3.386	136.09	0.047	59.71	0.685	-32.00	0.33	18.54
4.00	0.920	-43.04	3.381	129.89	0.053	54.85	0.670	-36.40	0.39	18.06
5.00	0.879	-53.83	3.378	117.91	0.062	45.72	0.638	-44.54	0.50	17.34
6.00	0.835	-64.32	3.428	106.08	0.070	38.30	0.604	-52.54	0.60	16.93
7.00	0.778	-77.53	3.525	92.97	0.081	29.68	0.553	-62.26	0.68	16.40
8.00	0.680	-92.29	3.539	78.21	0.086	17.34	0.469	-73.32	0.89	16.15
9.00	0.589	-109.87	3.527	63.32	0.091	7.85	0.398	-86.69	1.03	14.86
10.00	0.505	-127.92	3.432	49.90	0.089	0.93	0.335	-97.84	1.22	13.05
11.00	0.481	-149.57	3.490	35.80	0.096	-2.08	0.302	-114.77	1.14	13.32
12.00	0.461	-175.91	3.442	19.40	0.104	-10.23	0.250	-139.98	1.11	13.13
13.00	0.453	155.80	3.273	3.28	0.107	-18.84	0.210	-173.02	1.16	12.40
14.00	0.468	129.34	3.017	-12.03	0.104	-26.21	0.214	151.67	1.27	11.50
15.00	0.521	109.11	2.774	-25.92	0.102	-31.03	0.256	126.40	1.30	11.09
16.00	0.587	92.69	2.545	-39.53	0.098	-35.03	0.309	109.03	1.30	10.89
17.00	0.658	79.53	2.325	-53.80	0.098	-38.38	0.389	95.15	1.18	11.16
18.00	0.720	68.06	2.045	-67.87	0.096	-43.64	0.476	82.56	1.10	11.42
19.00	0.762	58.38	1.773	-79.76	0.093	-47.93	0.553	74.44	1.03	11.69
20.00	0.793	51.94	1.537	-89.63	0.089	-50.59	0.603	67.90	1.02	11.62
21.00	0.819	48.37	1.366	-97.66	0.089	-52.07	0.640	62.36	0.94	11.85
22.00	0.849	43.44	1.238	-106.37	0.090	-56.92	0.685	57.59	0.77	11.36
23.00	0.866	38.86	1.124	-116.19	0.089	-63.10	0.721	52.26	0.65	11.02
24.00	0.863	34.84	1.009	-124.88	0.087	-67.53	0.748	48.09	0.63	10.67
25.00	0.868	29.14	0.949	-132.34	0.084	-71.30	0.751	46.97	0.60	10.54
26.00	0.865	28.40	0.918	-138.91	0.086	-71.66	0.736	40.30	0.66	10.26
26.50	0.859	28.76	0.895	-143.63	0.084	-74.09	0.744	34.46	0.69	10.25

Note:

1. Gain Calculation:

$$MAG = \frac{|S_{21}|}{|S_{12}|} (K \pm \sqrt{K^2 - 1})$$

When  $K \leq 1$ , MAG is undefined and MSG values are used.  $MSG = \frac{|S_{21}|}{|S_{12}|}$ ,  $K = \frac{1 + |D|^2 - |S_{11}|^2 - |S_{22}|^2}{2 |S_{12} S_{21}|}$ ,  $D = S_{11} S_{22} - S_{21} S_{12}$

MAG = Maximum Available Gain

MSG = Maximum Stable Gain

**TYPICAL SCATTERING PARAMETERS** (TA = 25°C)

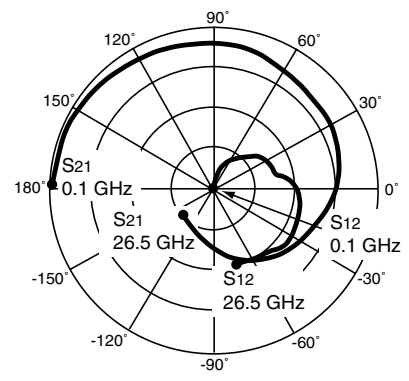
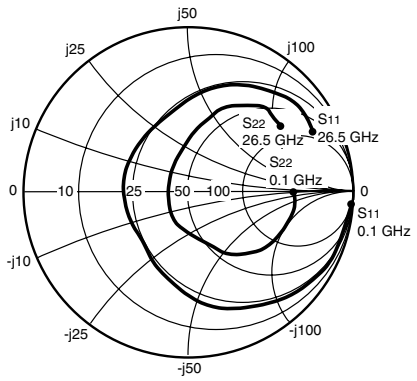

**Coordinates in Ohms  
Frequency in GHz  
VD = 2 V, ID = 10 mA**

**NE3210S01**  
**VD = 2 V, ID = 10 mA**

FREQUENCY GHz	S11		S21		S12		S22		K	MAG <sup>1</sup> (dB)
	MAG	ANG	MAG	ANG	MAG	ANG	MAG	ANG		
0.10	1.000	-1.27	4.899	178.46	0.001	88.31	0.654	-0.82	-0.03	36.47
0.20	1.000	-2.34	4.887	177.42	0.003	87.85	0.653	-2.00	-0.01	32.67
0.30	1.000	-3.43	4.884	176.29	0.004	88.67	0.653	-3.07	-0.01	31.02
0.40	0.999	-4.65	4.886	174.90	0.005	86.60	0.654	-3.96	0.04	29.78
0.50	0.996	-5.48	4.814	172.98	0.006	85.34	0.658	-4.64	0.10	28.83
0.70	0.993	-7.58	4.812	170.21	0.009	84.29	0.657	-6.56	0.13	27.34
1.00	0.989	-11.19	4.806	166.08	0.013	81.96	0.654	-9.07	0.16	25.79
1.50	0.980	-16.80	4.787	159.23	0.019	78.12	0.647	-13.65	0.19	24.05
2.00	0.967	-22.91	4.785	152.33	0.025	74.21	0.638	-17.91	0.25	22.83
2.50	0.951	-29.06	4.770	145.49	0.031	70.41	0.628	-22.27	0.30	21.88
3.00	0.931	-35.15	4.754	138.61	0.037	65.91	0.614	-26.72	0.36	21.12
3.50	0.908	-41.09	4.713	131.78	0.042	61.37	0.599	-31.08	0.43	20.49
4.00	0.882	-46.86	4.663	125.12	0.047	56.77	0.583	-35.15	0.50	19.99
5.00	0.825	-58.15	4.565	112.41	0.055	48.65	0.549	-42.36	0.64	19.22
6.00	0.766	-68.97	4.529	100.03	0.061	42.30	0.515	-49.21	0.75	18.73
7.00	0.694	-82.82	4.537	86.54	0.070	34.76	0.463	-57.82	0.84	18.10
8.00	0.582	-97.90	4.418	71.98	0.074	24.44	0.380	-66.37	1.06	16.21
9.00	0.488	-116.40	4.301	57.78	0.079	16.93	0.314	-77.56	1.18	14.77
10.00	0.407	-135.11	4.109	45.24	0.080	12.32	0.261	-85.89	1.33	13.66
11.00	0.394	-158.15	4.111	31.91	0.091	9.33	0.230	-102.84	1.21	13.79
12.00	0.391	173.89	3.994	16.52	0.102	1.30	0.173	-129.97	1.15	13.56
13.00	0.406	144.90	3.761	1.58	0.108	-7.33	0.132	-172.68	1.16	12.97
14.00	0.441	119.35	3.455	-12.50	0.109	-14.99	0.151	140.72	1.21	12.22
15.00	0.507	101.09	3.183	-25.26	0.111	-21.27	0.208	114.68	1.20	11.89
16.00	0.578	86.36	2.934	-37.87	0.109	-26.89	0.269	98.87	1.18	11.74
17.00	0.652	74.71	2.701	-51.30	0.110	-32.42	0.352	87.44	1.09	12.09
18.00	0.718	64.03	2.400	-64.66	0.108	-39.12	0.440	76.72	1.02	12.66
19.00	0.761	54.95	2.110	-75.90	0.105	-44.73	0.517	69.92	0.97	13.03
20.00	0.790	48.81	1.857	-85.48	0.100	-48.33	0.564	64.15	0.96	12.68
21.00	0.812	45.64	1.679	-93.42	0.100	-50.92	0.597	59.30	0.91	12.25
22.00	0.841	41.18	1.540	-102.29	0.100	-56.31	0.640	55.17	0.77	11.86
23.00	0.857	36.68	1.418	-112.28	0.098	-62.75	0.675	50.52	0.67	11.60
24.00	0.851	32.71	1.291	-121.28	0.095	-67.41	0.702	46.98	0.65	11.32
25.00	0.856	27.01	1.229	-129.13	0.092	-71.40	0.706	46.39	0.61	11.24
26.00	0.849	26.42	1.202	-136.41	0.094	-72.43	0.688	40.12	0.65	11.05
26.50	0.843	26.81	1.180	-141.30	0.093	-74.92	0.694	34.43	0.66	11.04

Note:

1. Gain Calculation:

$$MAG = \frac{|S_{21}|}{|S_{12}|} (K \pm \sqrt{K^2 - 1})$$

When  $K \leq 1$ , MAG is undefined and MSG values are used.  $MSG = \frac{|S_{21}|}{|S_{12}|}$ ,  $K = \frac{1 + |D|^2 - |S_{11}|^2 - |S_{22}|^2}{2 |S_{12} S_{21}|}$ ,  $D = S_{11} S_{22} - S_{21} S_{12}$

MAG = Maximum Available Gain  
MSG = Maximum Stable Gain

TYPICAL SCATTERING PARAMETERS (TA = 25°C)

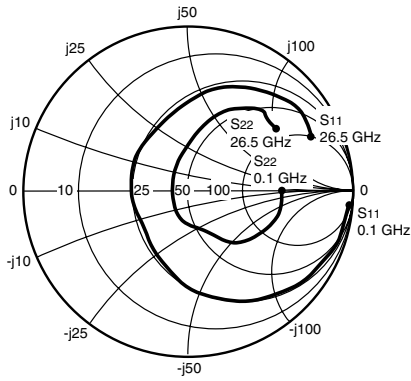

Coordinates in Ohms  
Frequency in GHz  
VD = 2 V, ID = 20 mA

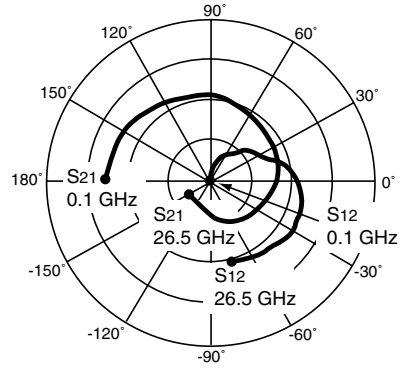

NE3210S01  
VD = 2 V, ID = 20 mA

FREQUENCY GHz	S11		S21		S12		S22		K	MAG <sup>1</sup> (dB)
	MAG	ANG	MAG	ANG	MAG	ANG	MAG	ANG		
0.10	1.001	-1.35	6.350	178.44	0.001	100.26	0.592	-0.73	-0.17	36.97
0.20	1.000	-2.51	6.337	177.12	0.002	90.28	0.589	-1.97	-0.01	34.46
0.30	1.000	-3.69	6.331	175.80	0.004	87.69	0.589	-2.99	0.01	32.52
0.40	0.998	-4.98	6.330	174.36	0.005	87.54	0.590	-3.85	0.05	31.37
0.50	0.995	-5.88	6.237	172.35	0.006	86.52	0.594	-4.39	0.11	30.44
0.70	0.991	-8.15	6.225	169.31	0.008	84.90	0.594	-6.19	0.15	28.93
1.00	0.986	-11.99	6.204	164.85	0.011	82.77	0.591	-8.54	0.19	27.38
1.50	0.974	-17.98	6.159	157.43	0.017	79.05	0.584	-12.82	0.24	25.64
2.00	0.956	-24.42	6.120	150.06	0.022	75.64	0.575	-16.80	0.31	24.38
2.50	0.934	-30.87	6.063	142.74	0.028	71.93	0.564	-20.81	0.38	23.41
3.00	0.908	-37.20	5.992	135.43	0.033	67.90	0.551	-24.92	0.45	22.62
3.50	0.878	-43.32	5.895	128.25	0.037	63.92	0.536	-28.84	0.53	21.97
4.00	0.845	-49.17	5.779	121.34	0.042	59.78	0.521	-32.40	0.61	21.43
5.00	0.777	-60.41	5.554	108.25	0.049	52.66	0.491	-38.43	0.76	20.57
6.00	0.709	-70.94	5.407	95.77	0.054	47.49	0.464	-44.02	0.88	19.97
7.00	0.630	-84.63	5.307	82.35	0.063	40.74	0.417	-51.35	0.96	19.23
8.00	0.513	-99.19	5.065	68.31	0.067	32.02	0.342	-57.35	1.16	16.31
9.00	0.420	-117.65	4.867	54.88	0.074	25.26	0.284	-66.38	1.25	15.21
10.00	0.342	-136.22	4.607	43.14	0.077	21.16	0.239	-72.34	1.34	14.25
11.00	0.334	-159.96	4.577	30.55	0.090	17.65	0.210	-88.57	1.21	14.32
12.00	0.340	170.90	4.426	15.93	0.102	9.26	0.146	-113.66	1.14	14.09
13.00	0.368	141.32	4.158	1.81	0.110	0.21	0.090	-161.41	1.13	13.54
14.00	0.412	115.91	3.825	-11.53	0.114	-8.01	0.112	135.76	1.16	12.85
15.00	0.485	98.43	3.540	-23.59	0.117	-15.36	0.177	108.58	1.14	12.57
16.00	0.560	84.46	3.281	-35.66	0.117	-21.73	0.242	93.80	1.11	12.45
17.00	0.638	73.45	3.045	-48.59	0.118	-28.19	0.327	83.95	1.04	12.92
18.00	0.709	63.12	2.727	-61.63	0.116	-35.54	0.419	74.18	0.98	13.70
19.00	0.755	54.05	2.418	-72.63	0.113	-41.78	0.496	67.89	0.94	13.32
20.00	0.787	47.82	2.146	-82.09	0.108	-46.06	0.543	62.26	0.92	12.99
21.00	0.807	44.84	1.962	-89.92	0.107	-49.01	0.573	57.59	0.88	12.63
22.00	0.837	40.34	1.815	-98.91	0.107	-54.84	0.614	53.81	0.77	12.29
23.00	0.852	35.93	1.686	-109.02	0.105	-61.41	0.648	49.53	0.67	12.07
24.00	0.846	31.86	1.548	-118.22	0.102	-66.55	0.675	46.40	0.64	11.83
25.00	0.849	26.10	1.488	-126.33	0.099	-70.76	0.677	46.14	0.59	11.77
26.00	0.840	25.54	1.467	-134.00	0.101	-72.25	0.655	40.16	0.62	11.62
26.50	0.835	26.02	1.446	-139.10	0.099	-74.52	0.660	34.52	0.63	11.63

Note:

1. Gain Calculation:

$$MAG = \frac{|S_{21}|}{|S_{12}|} (K \pm \sqrt{K^2 - 1})$$

When  $K \leq 1$ , MAG is undefined and MSG values are used.  $MSG = \frac{|S_{21}|}{|S_{12}|}$ ,  $K = \frac{1 + |D|^2 - |S_{11}|^2 - |S_{22}|^2}{2 |S_{12} S_{21}|}$ ,  $D = S_{11} S_{22} - S_{21} S_{12}$

MAG = Maximum Available Gain  
MSG = Maximum Stable Gain

## NE3210S01 NONLINEAR MODEL

## SCHEMATIC

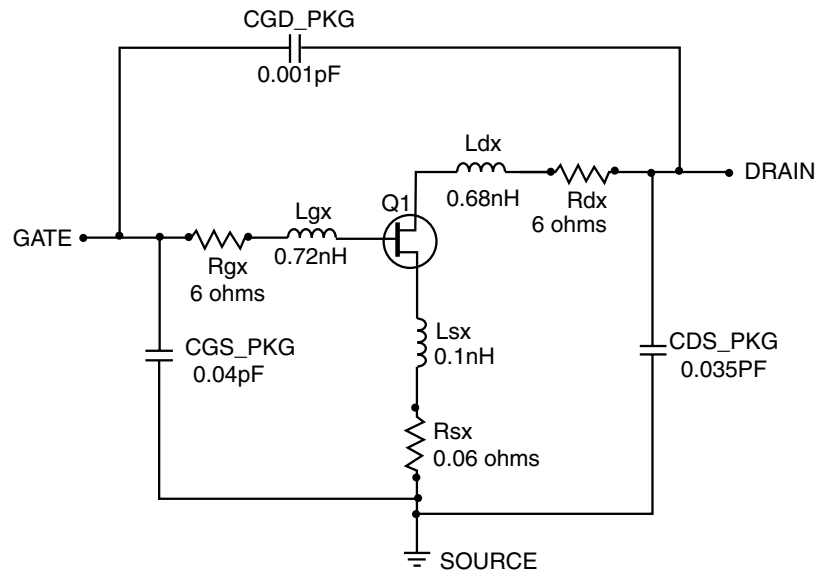
FET NONLINEAR MODEL PARAMETERS <sup>(1)</sup>

Parameters	Q1	Parameters	Q1
VTO	-0.798	RG	8
VTOSC	0	RD	0.5
ALPHA	8	RS	3
BETA	0.0952	RGMET	0
GAMMA	0.072	KF	0
GAMMADC	0.065	AF	1
Q	2.5	TNOM	27
DELTA	0.5	XTI	3
VBI	0.6	EG	1.43
IS	1e-14	VTOTC	0
N	1	BETATCE	0
RIS	0	FFE	1
RID	0		
TAU	4e-12		
CDS	0.12e-12		
RDB	5000		
CBS	1e-9		
CGSO	0.36e-12		
CGDO	0.014e-12		
DELTA1	0.3		
DELTA2	0.6		
FC	0.5		
VBR	Infinity		

(1) Series IV Libra TOM Model

## Life Support Applications

These NEC products are not intended for use in life support devices, appliances, or systems where the malfunction of these products can reasonably be expected to result in personal injury. The customers of CEL using or selling these products for use in such applications do so at their own risk and agree to fully indemnify CEL for all damages resulting from such improper use or sale.

**CEL** California Eastern Laboratories, Your source for NEC RF, Microwave, Optoelectronic, and Fiber Optic Semiconductor Devices.

4590 Patrick Henry Drive • Santa Clara, CA 95054-1817 • (408) 919-2500 • FAX (408) 988-0279 • [www.cel.com](http://www.cel.com)

DATA SUBJECT TO CHANGE WITHOUT NOTICE

## UNITS

Parameter	Units
time	seconds
capacitance	farads
inductance	henries
resistance	ohms
voltage	volts
current	amps

## MODEL RANGE

Frequency: 0.1 to 22.5 GHz

Bias:  $V_{DS} = 1\text{ V to }3\text{ V}$ ,  $I_D = 5\text{ mA to }30\text{ mA}$

Date: 1/99